

BROKK 400

UPGRADED!



Even more heavy-duty demolition power

THE NEW BROKK 400 offers higher capacity and robustness, along with its renowned mobility and versatility. All parts of the undercarriage are upsized to make it the perfect machine for all applications that require extensive tracking. The upgraded hydraulic system and improved stability gives you an unparalleled performance even with the most demanding tools. With a reach of almost 7 meters (23.1 feet) and a full 360-degree turning radius, the Brokk 400 provides excellent access to the work area without the need for time-consuming repositioning.

APPLICATIONS

A favorite for the toughest heavy-duty work, such as removing heavily-reinforced concrete vaults and foundations with speed and accuracy.

The Brokk 400 weighs 5100 kg and can handle tools up to 600 kilos in weight. With this impressive power-to-weight ratio, the machine has the muscles to take on heavily-reinforced concrete structures while eliminating the need for expensive shoring. It's also very productive in open spaces. And in all applications, the operator remains at a safe distance, away from vibration and falling debris.

RANGE

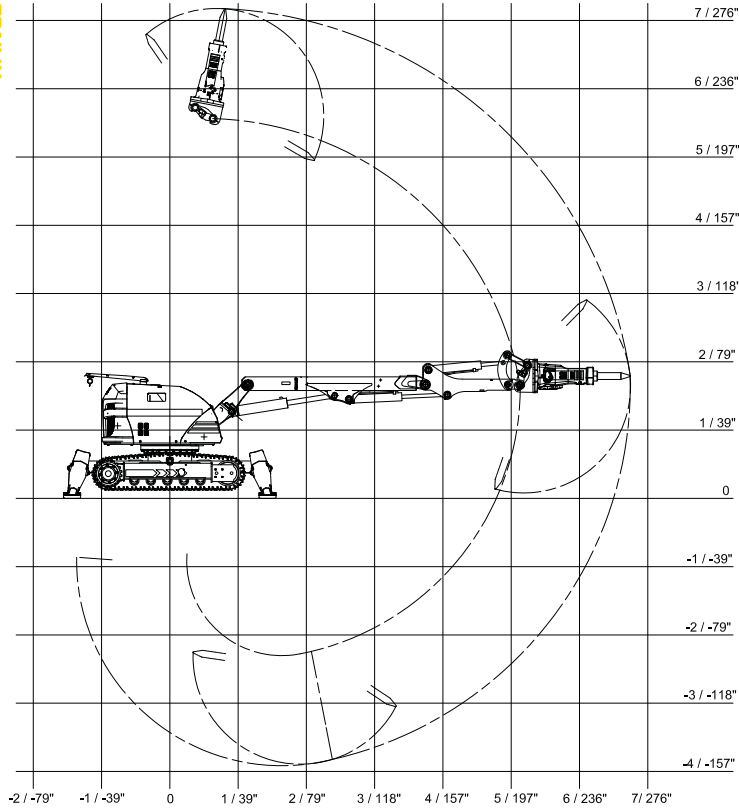

SIZE

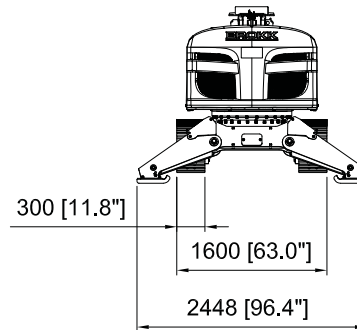
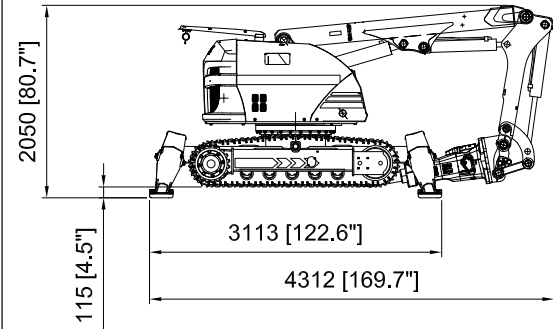
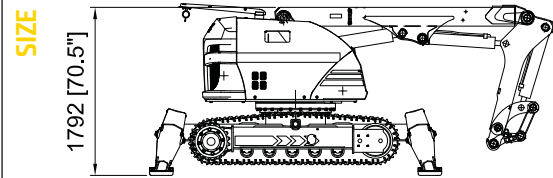

TECHNICAL DATA

Hydraulic breaker in illustrations SB 552
 Load and stability diagram can be ordered from Brokk AB

Performance

Slewing speed 20 sec/360°
 Transport speed, max. 2.5 km/h; 0.7 m/s; 1.6 mph
 Incline angle, max. 30°

Hydraulic system

Hydraulic system capacity 160 l; 42.3 US gal
 Pump type Variable load-sensing piston pump
 System pressure to cylinders, attachment and motors, max. 17.0 MPa; 2,466 psi
 System pressure, increased to attachment, max 23.0 MPa; 3,336 psi
 Pump flow max* 50 Hz 115 l/min; 30.4 US gal/min
 60 Hz 130 l/min; 34.3 US gal/min

Electric motor

Type ABB
 Output** 30kW
 Current** 65A
 Starting device Soft start/Direct start

Control system

Control type Portable control box
 Signal code Digital
 Transfer Cable/Radio

Weight

Weight of base machine excl. attachment 5,100 kg; 11,240 lbs
 Recommended max. attachment weight 600 kg; 1,323 lbs

Noise level

Sound power level Lwa, measured according to directive 2000/14/EC 100 dB (A)

* Max pump flow and max system pressure cannot be delivered at the same time as the engine will overload
 ** Valid for 400V/50Hz

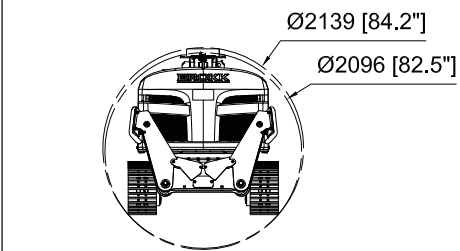

TOOLS



DOWNLOAD THE LEAFLET - SCAN THE QR CODE

